

KATO CES

Zero Tail Swing Mini Excavator

V Four HD35



Comfortable EVOLUTION

COMFORTABLE OPERATOR ROOM AND EASY MANIPULATION



• Easily visible monitor

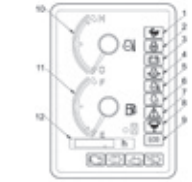

- 1 Travel speed indicator
- 2 Glow indicator
- 3 Battery charge warning indicator
- 4 Engine oil pressure warning indicator
- 5 Water temperature warning indicator
- 6 Auto idle indicator
- 7 Control lock warning indicator
- 8 Water-separator warning indicator
- 9 ECO mode indicator
- 10 Water temperature gauge
- 11 Fuel gauge
- 12 Hour meter

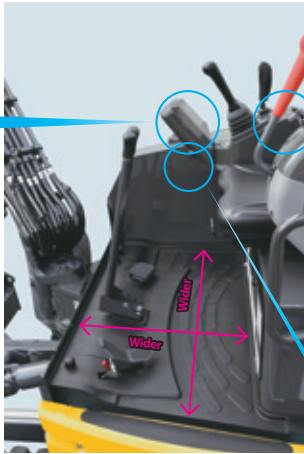

• Leg room enlarged by 20%
 • Cabin room enlarged by 25%
 *In comparison with our former model



- Centralized switches (Right console box)
- A Engine starter switch
- B Throttle dial
- C Auto Idle selector switch
- D Light switch
- E Work mode selector switch



• Spare power port (12V 10A)

High Performance EVOLUTION

HIGH POWER DIGGING AND QUICK RESPONSE

- Digging force increased by 10%
 *In comparison with our former model
- Quickly responsive 4-pump system

EASY MAINTENANCE

- Large covers for easier access



• Right hand cover



• Engine room

Safety EVOLUTION

WORLD-STANDARD SAFETY

- ROPS/TOPS Compliance Operator Cab and Canopy
- ROPS/TOPS Canopy (std.)
- ROPS/ TOPS Cab (opt.)
- FOPS Cab (opt.)



ROPS/TOPS Cab (opt.)

ERROR-PREVENTION

- All-lever lock
- Neutral engine-start
- Auto-parking brake in swing & traction motors



All operations are blocked when the lever is raised.

Hydraulic tank with air breather



Large fuel filter



Water-separator



*The warning indicator turns on if water is collected up to the specified level.

EASY FUEL REFILLING

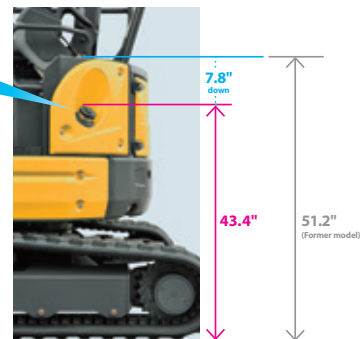

LOW FUEL CONSUMPTION

24% FUEL SAVINGS

From the New Auto Idle and Eco Mode Features.
 *In comparison with our former model

Refilling position (unit : inches)



■ Dimensions

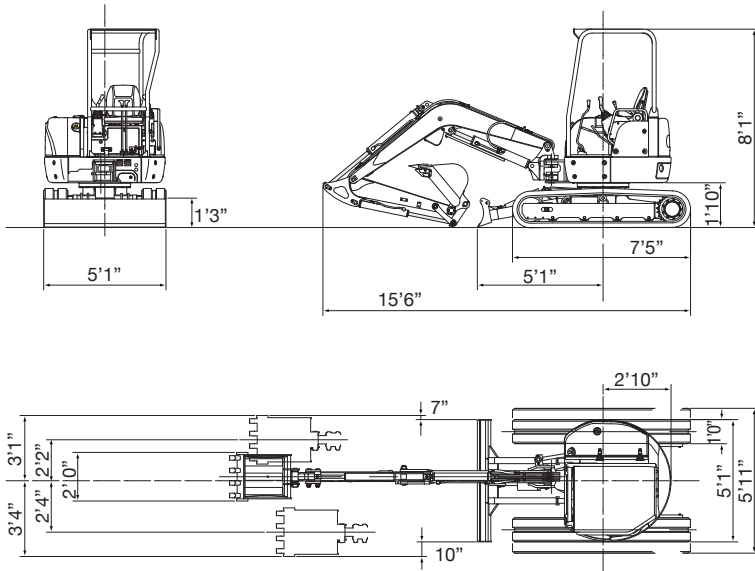

■ Working Range

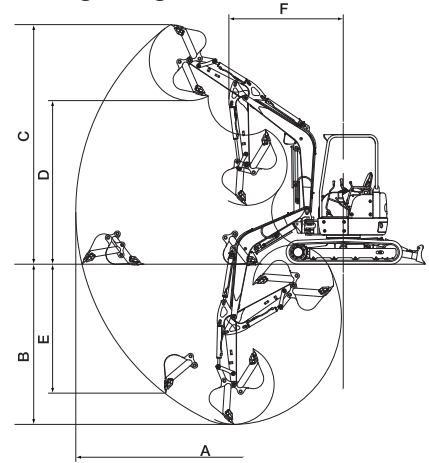

	4-Post or Cabin	Side Arm min/max
A Max. digging radius	17'9"	17'1"/19'9"
B Max. digging depth	11'4"	10'4"/13'1"
C Max. digging height	16'2"	15'7"/17'2"
D Max. dumping height	11'1"	10'10"/12'6"
E Max. vertical digging depth	9'8"	7'8"/10'3"
F Min. front turning radius	7'2"	7'7"
At right boom swing	5'8"	6'2"

■ 35V4 Specifications

Performance		Boom swing system	
Bucket capacity	3.9 cu. ft.	Type	Boom offset with hydraulic cylinder
Bucket width	24"	Swing angle (L/R)	50°/80°
Operating weight: 4-Post (Cabin)	8,100 lbs. (8,450 lbs.)	Hydraulic system	
Transportation weight: 4-Post (Cabin)	7,606 lbs. (7,956 lbs.)	Pressure	3,554 psi
Swing speed	9.0 min ⁻¹	Pump •type/ hydraulic flow	2 Piston/2 Gear • 9.9 gpm x 2 + 6.1 gpm
Travel speed (low/high)	1.7/3.0 mph	Dozer blade	
Gradeability	30°	Size	61"x15"
Ground pressure	4.2 psi	Lift above ground / Drop below ground	15.2"/17"
Max bucket digging force	7,688 lbs.	Max auxiliary flow	
Engine		1st line	16 gpm
Model	YANMAR 3TNV88 Tier 4 Final	2nd line (optional)	6.1 gpm
Rated output	22.8 hp/2,200 rpm		
Fuel tank capacity	11.1 gallons		

Optional Attachments:

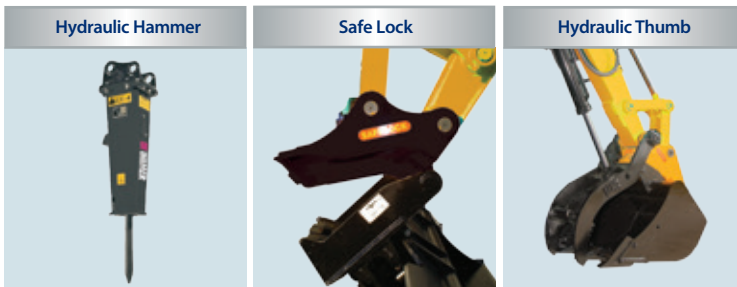

Photographs may differ in some cases from actual objects. Specifications are subject to change without notice due to technical improvements or modifications.

Features:



COMPACT EXCAVATOR SALES, LLC
 400 Production Court • Elizabethtown, KY 42701
 Phone: 800.583.1447 • Fax: 270.737.0419
 WWW.KATOCES.COM